

Помпи центробежни самозасмукващи за чиста вода

 Clean water
  Domestic use
  Civil use



PERFORMANCE RANGE

- Flow rate up to **70 l/min** (4.2 m³/h)
- Head up to **58 m**

APPLICATION LIMITS

- Manometric suction lift up to **9 m** (HS)
- Liquid temperature between **-10 °C** and **+40 °C**
- Ambient temperature up to **+40 °C**
- Max. working pressure **6 bar**
- Continuous service **S1**

CONSTRUCTION AND SAFETY STANDARDS

EN 60335-1
IEC 60335-1
CEI 61-150

EN 60034-1
IEC 60034-1
CEI 2-3



CHARACTERISTIC CURVES AND PERFORMANCE DATA

50 Hz | n = 2900 min⁻¹ | HS = 0 m

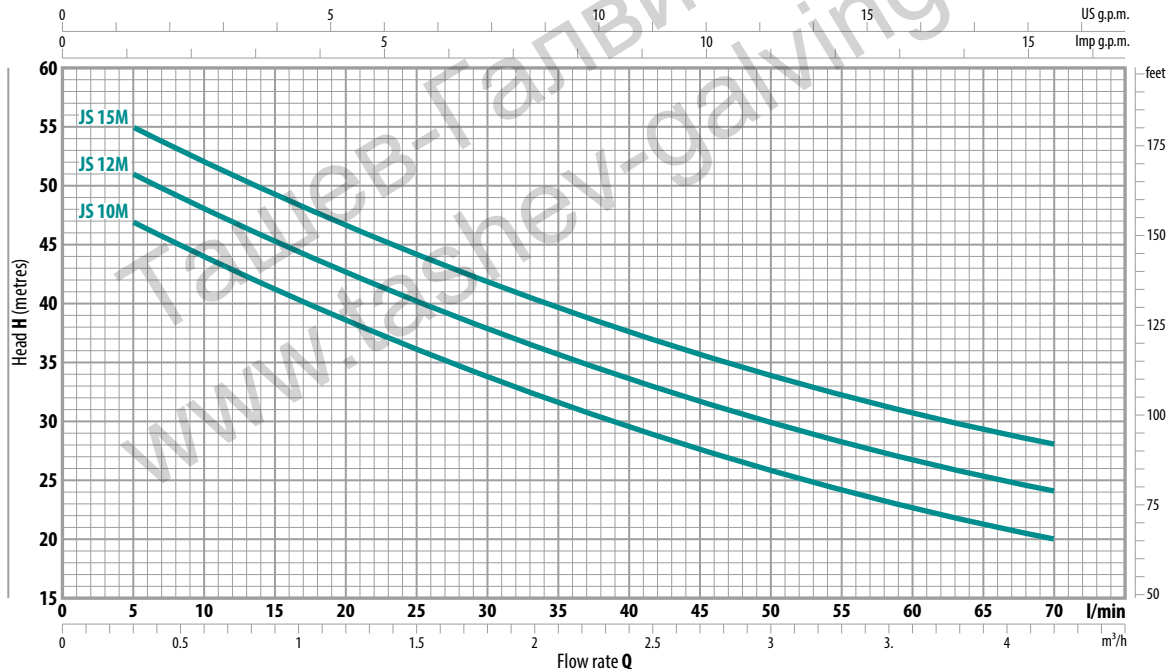

MODEL		POWER (P ₂)		Q	Flow rate											
Single-phase	Three-phase	kW	HP		0	0.3	0.6	1.2	1.5	1.8	2.4	2.7	3.0	3.6	4.2	
				l/min	0	5	10	20	25	30	40	45	50	60	70	
JS 10M	JS 10	0.75	1	H metres	50	47	44	38.5	36	34	29.5	27.5	26	22.5	20	
JS 12M	JS 12	0.90	1.25		54	51	48	42.5	40	38	33.5	31.5	30	26.5	24	
JS 15M	JS 15	1.1	1.5		58	55	52	46.5	44	42	37.5	35.5	34	31	28	

Q = Flow rate
 H = Total manometric head
 HS = Suction height

Tolerance of characteristic curves in compliance with EN ISO 9906 Grade 3B.

INSTALLATION AND USE

Suitable for use with clean water and liquids that are not chemically aggressive towards the materials from which the pump is made. The self-priming JS pumps are designed to pump water even in cases where air is present. Because of their reliability and the fact that they are easy to use, they are recommended for use in domestic applications such as the distribution of water in combination with small or medium sized pressure tanks, and for the irrigation of gardens and orchards, etc. The pump should be installed in an enclosed environment or sheltered from inclement weather.

CONSTRUCTION CHARACTERISTICS

PUMP BODY	Cast iron with an Epoxy Electro Coating treatment, with threaded ports in compliance with ISO 228/1
IMPELLER	Stainless steel AISI 304
MOTOR SHAFT	Stainless steel EN 10088-3 - 1.4104
MECHANICAL SEAL	Ceramic - Graphite - NBR
ELECTRIC MOTOR	The three-phase pumps are fitted with high performance motors in class IE3 (IEC 60034-30)

DIMENSIONS AND WEIGHT

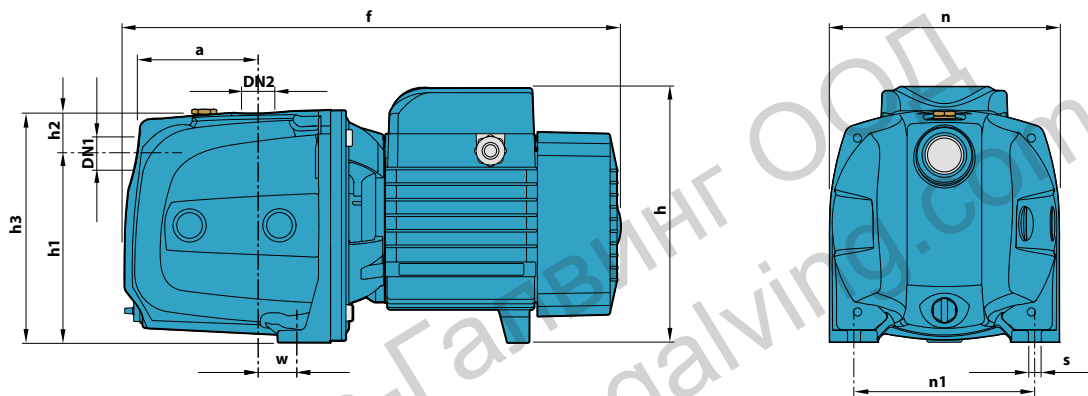

MODEL		PORTS		DIMENSIONS mm										kg	
Single-phase	Three-phase	DN1	DN2	a	f	h	h1	h2	h3	n	n1	w	s	1~	3~
JS 10M	JS 10	1"	1"	96	388	201 *	147	33	180	180	142	22	10	13.0	13.0
JS 12M	JS 12													14.0	14.0
JS 15M	JS 15													14.2	14.2

(*) h=220 mm for single phase versions at 110 V

ABSORPTION

MODEL	VOLTAGE		
	230 V	240 V	110 V
Single-phase	230 V	240 V	110 V
JS 10M	4.7 A	4.5 A	9.4 A
JS 12M	5.8 A	5.3 A	11.6 A
JS 15M	6.0 A	5.5 A	12.0 A

MODEL	VOLTAGE					
	230 V	400 V	690 V	240 V	415 V	720 V
Three-phase	230 V	400 V	690 V	240 V	415 V	720 V
JS 10	3.5 A	2.0 A	1.2 A	3.4 A	1.9 A	1.1 A
JS 12	4.6 A	2.7 A	1.6 A	4.4 A	2.5 A	1.5 A
JS 15	5.1 A	3.0 A	1.7 A	4.9 A	2.8 A	1.6 A

PALLETIZATION

MODEL		GROUPAGE	CONTAINER
Single-phase	Three-phase	n. pumps	n. pumps
JS 10M	JS 10	72	96
JS 12M	JS 12	72	96
JS 15M	JS 15	72	96